

SPECIFICATIONS	
CONTACT CARRIER MATERIAL/COLOR	TPU/YELLOW
MOLDED HEAD MATERIAL/COLOR	TPU/BLACK
CONTACT MATERIAL/PLATING	BRASS/GOLD
COUPLING NUT MATERIAL/PLATING	BRASS/NICKEL
RATED CURRENT [A]	9.0 A
RATED VOLTAGE [V]	250 V
TEMPERATURE RATING	-40°C TO +80°C (-40°F TO +176°F)
PROTECTION CLASS	MEETS NEMA 1,3,4,6P AND IEC IP67

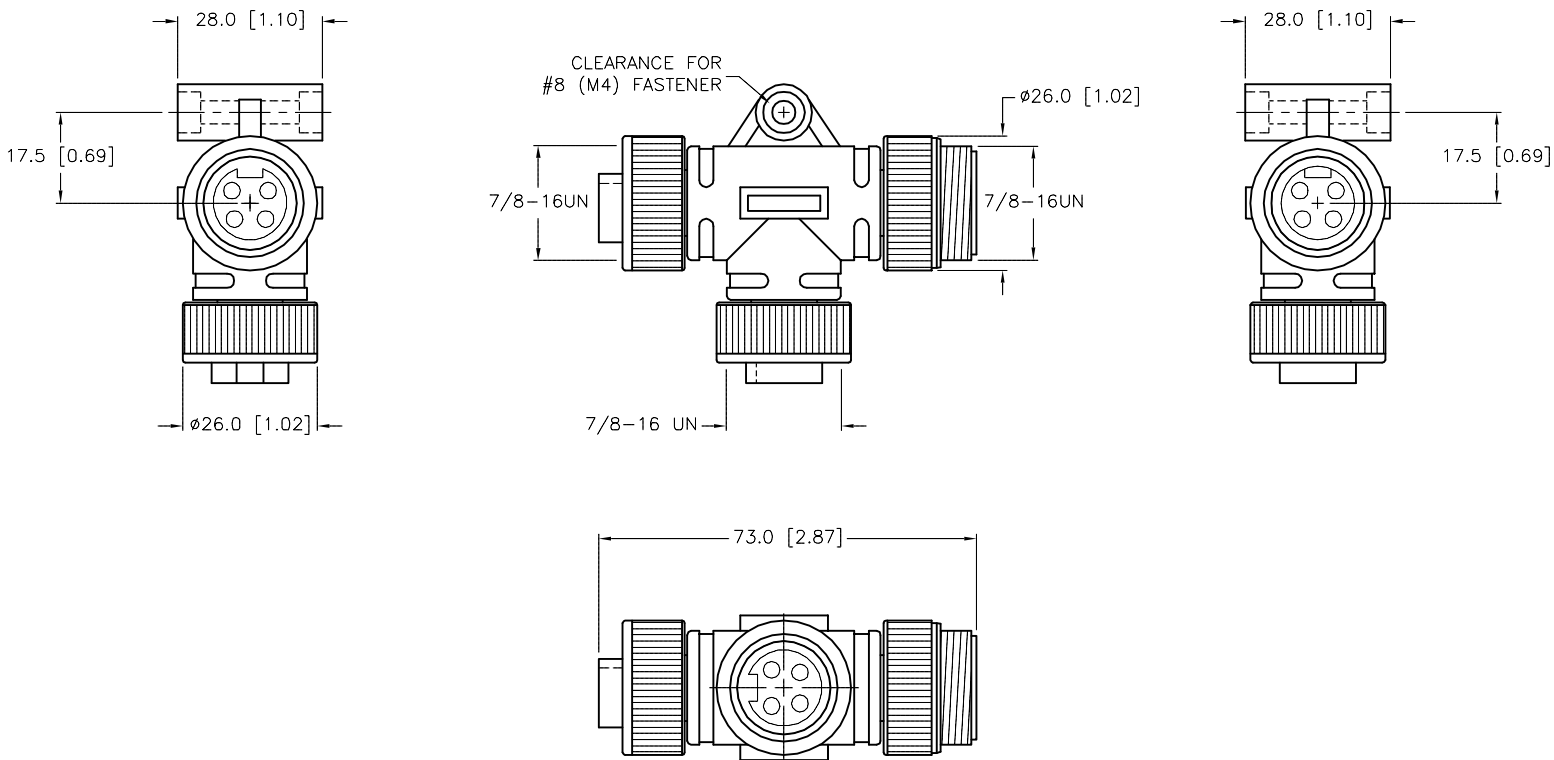

SOURCE DRAWING - FOR REFERENCE ONLY

NOTES:

- "KF" DESIGNATES KEYWAY OF DROP CONNECTOR FACES TOWARD THE FEMALE CONNECTOR.
- "/S771" DESIGNATES BLACK MOLDED PLUG BODY.

RELATED DOCUMENTS		3RD ANGLE PROJECTION		THIS DRAWING IS CONFIDENTIAL AND THE PROPERTY OF TURCK INC. USE OF THIS DOCUMENT WITHOUT WRITTEN PERMISSION IS PROHIBITED.				3000 CAMPUS DRIVE MINNEAPOLIS, MN 55441 1-800-544-7769 (763) 553-7300 (763) 553-0708 fax www.turck.us	
1.			DRFT NF		DATE 09/04/20	DESCRIPTION RSM-2RKM 40-KF/S771			
2.			APVD J.B.		SCALE 1=1.5				
MATERIAL		ALL DIMENSIONS DISPLAYED ON THIS DRAWING ARE FOR REFERENCE ONLY		UNIT OF MEASUREMENT MILLIMETER [INCH]		IDENTIFICATION NO. 100023423		REV A	
SEE SPECIFICATIONS									
FINISH		CONTACT TURCK FOR MORE INFORMATION		DO NOT SCALE THIS DRAWING		FILE: 100023423		SHEET 1 OF 1	
SEE SPECIFICATIONS									
A	DRAWING RELEASE	RDS	09/10/20						
REV	DESCRIPTION	BY	DATE	ECO NO.					